

Storm Drain Measuring Guidelines

For a *Square Grate & Circular Inlet* **Spill Safe™ Safe Drain™**

Follow these steps to properly measure the grate and the interior dimensions of the drain.

Step 1: Determine the type of grate you have – *flat* or *deep-cut*. A deep-cut grate has an inset portion that extends down into the storm drain opening, and is thicker than a flat grate (see drawing). Indicate your grate type below.

- Flat cut grate
 Deep-cut grate

Step 2: For either *flat* or *deep-cut* grate, measure the exterior edge of the grate. Indicate these measurements (Dimension **A** = length; Dimension **B** = width) in the spaces below.

Dimension **A** = _____

Dimension **B** = _____

For *deep-cut* grate only, measure the exterior edge of the inset part of the grate that extends down into the storm drain opening. Indicate these measurements (Dimension **C** = length; Dimension **D** = width) in the spaces below.

Dimension **C** = _____

Dimension **D** = _____

Step 3: The Safe Drain catch basin requires a minimum depth clearance of 12 inches to properly fit into the storm drain. Insure that the interior storm drain walls are smooth and have no protrusions for at least 12 inches down into the drain opening.

Step 4: Measure interior width (**E**) and length (**F**) of storm drain inlet opening and indicate these measurements below.

Dimension **E** = _____

Dimension **F** = _____

Measure the diameter of circular storm drain inlet opening and indicate these measurements below.

Dimension **G** = _____

Measurements Taken By:

LEGEND	
A	= Exterior width of flat grate/deep-cut grate
B	= Exterior length of flat grate/deep-cut grate
C	= Exterior width of inset portion (deep-cut grates only)
D	= Exterior length of inset portion (deep-cut grates only)
Minimum 12 inch clearance for catch basin	
E	= Interior width of rectangular storm drain inlet
F	= Interior length of rectangular storm drain inlet
G	= Interior diameter of circular storm drain inlet

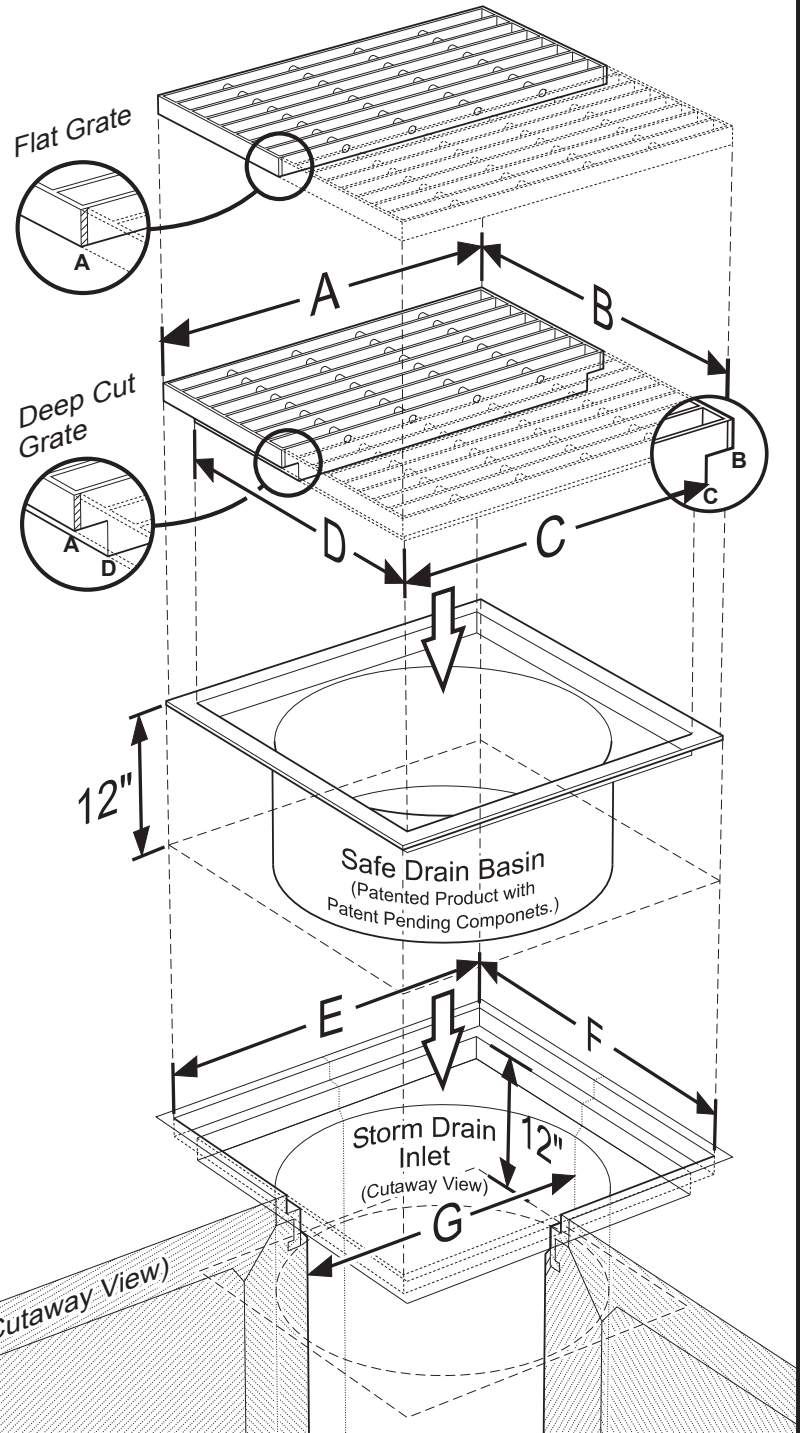

If you have questions contact Safe Drain's Northeast Distributor, stormwaterworks.com
 phone: 203-324-0045/fax: (203) 324-0075.

It would be very helpful if digital photos could be provided which show 1) a full view of the open catch basin including the grate collar area and 2) a full view of the bottom of the grate.